

TAKADA AUTOMATIC TRANSFER SWITCHES

# TGM-E

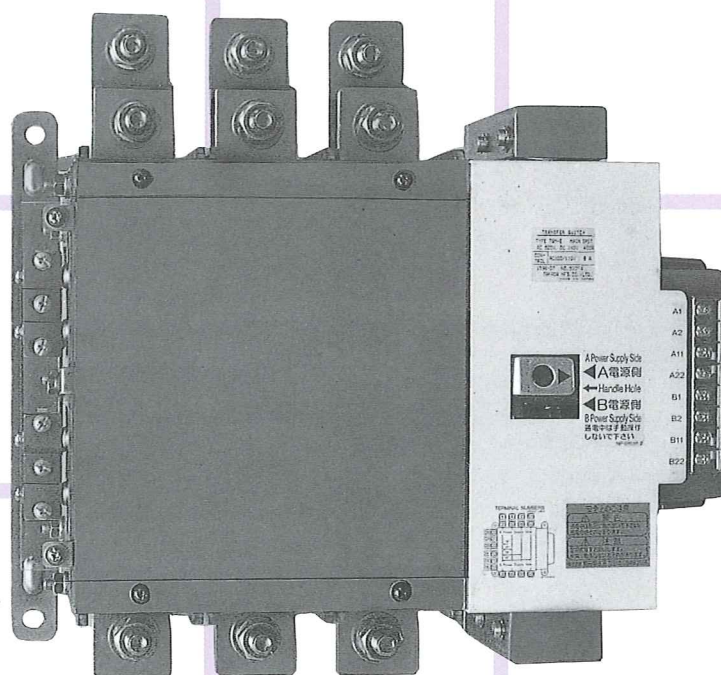

TAKADA WORKS CO., LTD.

## ■ PREFACE

TGM-E TYPE TRANSFER SWITCH is a change-over switch which changes over the power sources of 2 systems by an electromagnetic coil only instantaneously and supplies electric power to load. Electric power is supplied to the electromagnetic coil at the time of change-over action. An instantaneous exciting machine holding type mechanism that power consumption is normally zero has been adopted for the purpose of holding the contact condition of contacts mechanically after action.

TGM series are adopted in a wide application field i.e. change over of commercial power and emergency one (generator, battery etc.) represented by co-generation system and commercial power for many years.

## ■ SPECIFICATIONS

Rated voltage		AC600V DC140V						AC600V						
Rated current		30A, 60A 100A	150A	200A	300A 400A	500A 630A	800A	1000A	1200A 1600A	2000A 2500A	3150A (NOTE 5)			
Operating current Operating voltage variable range 80-120%	Pole	1P-4P				1P-3P	4P	1P-3P	4P	1P-4P	1P, 2P, 3P, 4P	1P, 2P	3P	
	AC100/110V	3.5A	3.5A	6A	8A	8A	11A	19A	27A	27A	19A	33A	19A	33A
	AC200/220V	1.7A	1.7A	2.5A	5A	5A	7A	9A	12A	12A	9A	17A	9A	17A
	DC24V	19A	19A	22A	29A	38A	48A	64A	86A	86A	64A	103A	64A	103A
	DC48V	6.5A	6.5A	11A	17A	17A	25A	31A	41A	41A	31A	49A	31A	49A
	DC100/110V	3.5A	3.5A	6A	8A	8A	11A	19A	27A	27A	19A	33A	19A	33A
	DC00/220V	1.7A	1.7A	2.5A	5A	5A	7A	9A	12A	12A	9A	17A	9A	17A
Full operating time (NOTE 3) (with aux. relay)		60msec (80msec)	60msec (80msec)	65msec (85msec)	70msec (90msec)	80msec (150msec)	100msec (170msec)	100msec (170msec)	160msec (230msec)	190msec (260msec)	190msec (260msec)			
Contacts OFF time (NOTE 4)		13msec	13msec	18msec	20msec	25msec	25msec	25msec	25msec	25msec	32msec	32msec		
Rated short time withstand current		5KA 1.5Hz 1KA 1sec	10KA 1.5Hz 1KA 1sec	10KA 1.5Hz 2KA 1sec	10KA 1.5Hz 4KA 1sec	12KA 3Hz 6KA 1sec	16KA 3Hz 10KA 1sec	20KA 3Hz 10KA 1sec	30KA 3Hz 15KA 1sec	50KA 3Hz 20KA 1sec	50KA 3Hz 25KA 1sec			
Switching capacity		1.5times as large as rated current MAKE-BREAK AC-POWER FACTOR:0.8, DC-time constant: non-induction so far as possible												
Switching durability	Mechanical	more than 50000 times					more than 10000 times							
	Electrical	more than 250000 times					more than 50000 times							
Switching cycle		Once/1 min.						Once/2 min.		Once/4 min.				
Connection system		Surface connection (F) only		Surface connection (F). Back side connection type (B)				Back side connection type (B) only						
		The standard side of the surface connection type load side terminal is up side. As for the down side of terminal at loadside, it is optional.												
		All auxiliary contacts and control terminal are of front connection												
Construction of insulation cover		Dust-proof mold type Front side shock preventive type				The surface connection type is provided with main terminal cover								
Auxiliary relay		The auxiliary relay built-in type (RY) is optional												
Auxiliary contacts		OMRON type micro-switch: X-10GW-B Provided with 1C each at up and down												
Withstand voltage		AC 2500V for 1 minute												
Insulation resistance		Higher than 50 MΩ (1000V megger) Coil E class insulation												
Drop of voltage		100mV or less between terminals												
Rise of temp		Less than 75°C at contact parts (silver alloy)												
Reference standards		JEM 1465 AC-31A class, DC-31A class, IEC 947-3												
Standard operating condition conforming to JEM1465		Above sea level: Lower than 2000m, Ambient temperature: -5 ± 40°C Relative humidity: 45~85% At the condition where it is not subjected to abnormal vibration or shock. In the atmosphere free from too much water vapour, oil vapour, smoke, dust and dirt, salt, corrosive substance.												

### (NOTES)

1. If the rated operation voltage exceeds 220V, prepare a transformer in order to make it to be 220V, and then order from us.
2. The capacity of operating power transformer must be the rated operation voltage x rated operation current x 1/3=1 [ ] VA or higher.
3. The full operation time means the time up to arrival the main contacts at changed-over side after receiving a signal at the coil.
4. The contact OFF time means the time up to arrival of the main contacts at B power side from starting the separation of main contacts at A power side at no-load condition (or the contrary).
5. 4P 3150A is of special specification. ( Inform us about the details). \*Possible to manufacture the unit with 4000A in the rated current.
6. If the ambient temperature exceeds +40°C, the reduction ratio of the rated current must be 90% at +50°C.



# OPERATION CIRCUIT DIAGRAM

30A~3150A

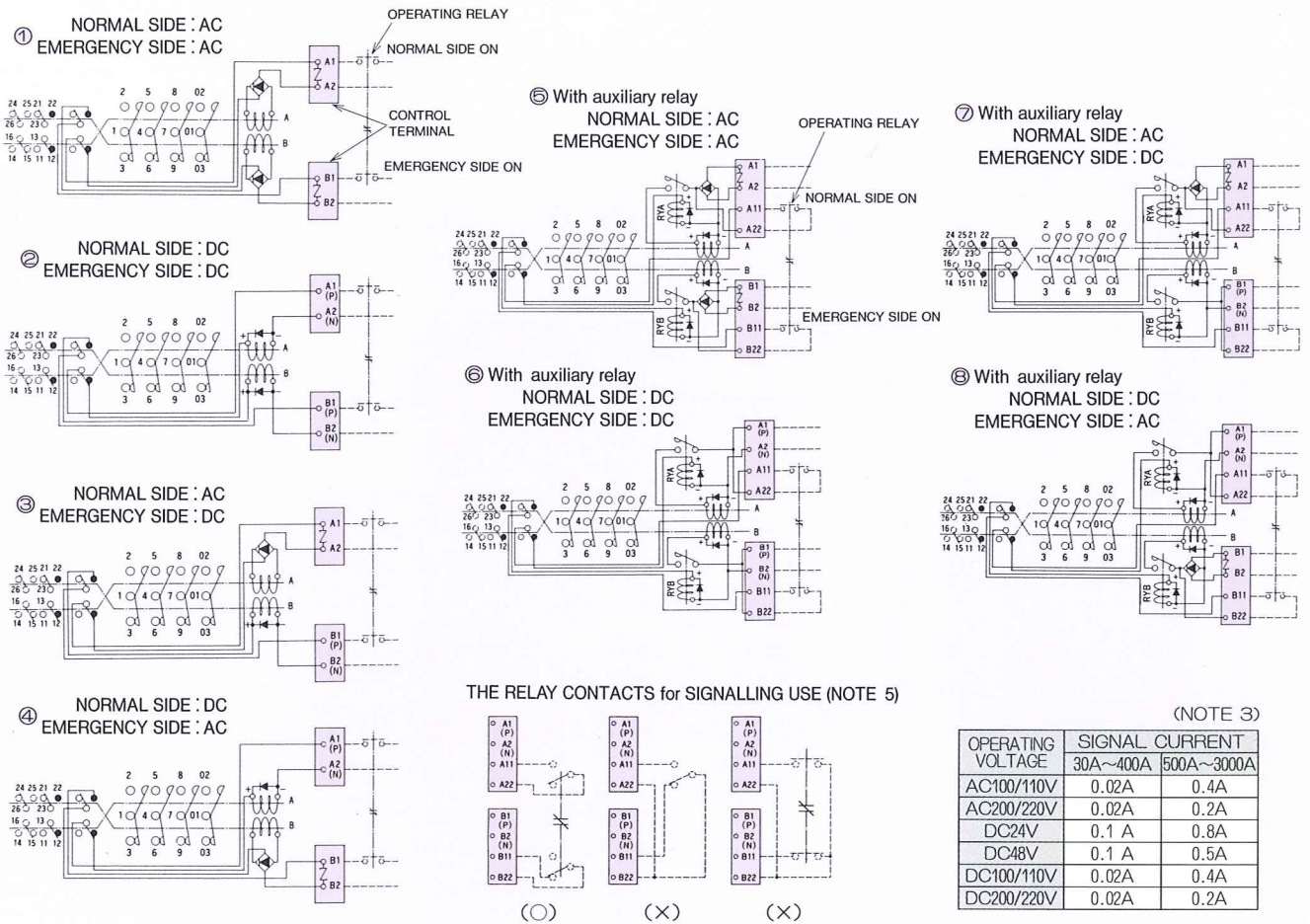

**(NOTES)**

1. The coil has an instantaneous rating. It has been so designed that the coil current is turned off with a microswitch (auxiliary relay) inside after completion of change-over action.
2. In the case of DC operation, the control terminal has a marking of polarity. Paying attention for wiring. If connected oppositely, internal elements will be damaged.
3. Make selection on the contactants of the relay for external operation, matching the operation voltage and operation current. If selection is made in a wrong way, the relay contacts will be seized molten or poor action of the switch body, be caused.
4. Make selection on the relay contacts for signalling, matching the operation voltage and operation current. If selection is made in a wrong way, the relay contacts will be seized molten or poor action of the switch body, be caused.
5. Use the relay contacts for signalling use which are independent individually. With the one side terminal in common, if C contacts etc. are used, it will not be put in action.
6. In order to assure a reliable operation, set the command time longer than 1 second for each control signal. Set the sequence in such a way that the action commands to A coil and B one are not inputted at the same time. If not, poor performance will be caused.
7. Do not carry out the change-over action repeatedly and continuously at a shorter interval than specified. If not, the coil will be overheated, resulting in causing poor performance or burning damage of coil.
8. The operation power voltage shall not be over the specified range. If over, poor performance will be caused.

## CAUTIONS FOR USE

1. Avoid using the unit in such a place where ambient temperature is high nor humidity is high nor injurious gas is generated.
2. Install this unit on a plane surface where vibration is generated little and vertically in such a direction that the name plate of the body can be read correctly. Use such bolts as suited for the fitting hole.
3. Use the electric cables and bus bar to be connected with the main terminal, meeting fully the requirements and bus bar, tighten bolts reliably and positively.
4. When the operation current is large, full attention must be paid to the selection of electric cables of the operation circuit. If the cable is small or far away the power supply extremely, a voltage drop will be caused due to the electric cable, resulting in causing poor performance sometimes.
5. If manual operation is carried out, do so after turning off the main circuit power and operation power. If not, the contacts will be seized welding or coil burnt damaged.
6. Make inspection and maintenance for carrying out the smooth operation of the switch and maintenance of performance. Refer to the paragraph of INSPECTION AND MAINTENANCE of the operation manual for the details.

# DIMENSIONS

## 30A~100A

Surface connection type

- ① Terminal at load side
- ② Terminal at A power source side
- ③ Terminal at B power source side
- ④ Control terminal
- ⑤ Auxiliary contact
- ⑥ Manual handle (insertion type)
- ⑦ Hole for manual handle
- ⑧ Main terminal cover

\* In the case of "with 2c", it will become Max.30.

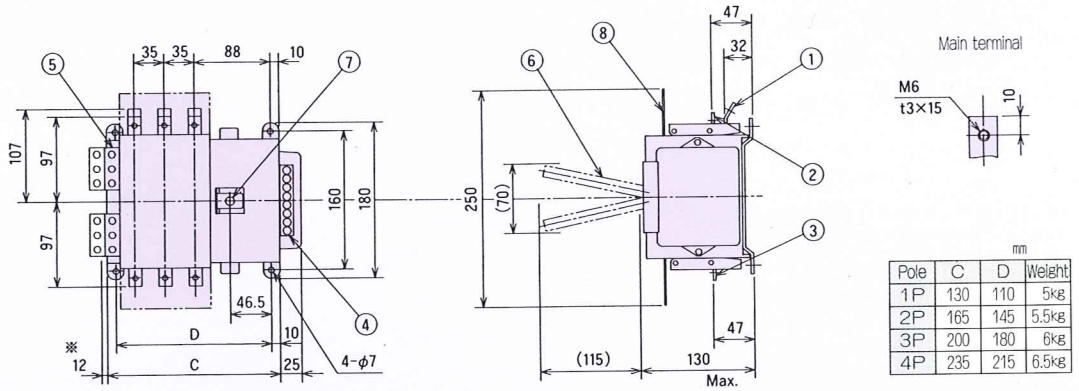

## 150A

Surface connection type

\* In the case of "with 2c", it will become Max.30.

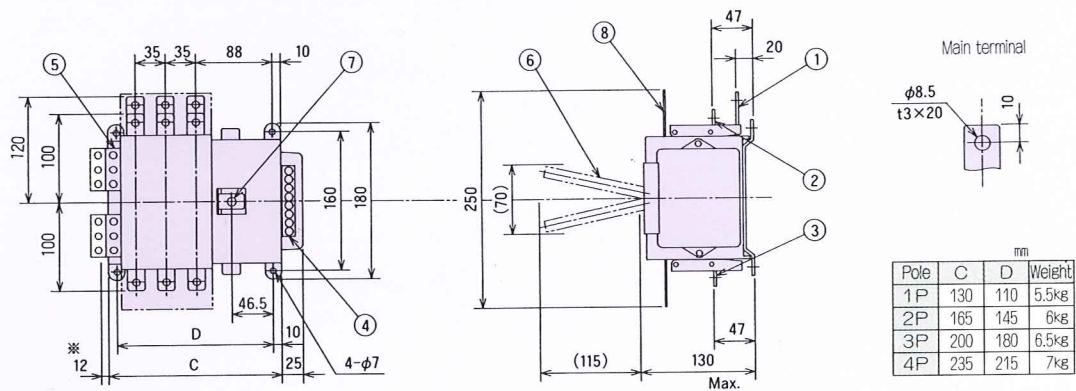

## 200A

Surface connection type

\* In the case of "with 2c", it will become Max.30.

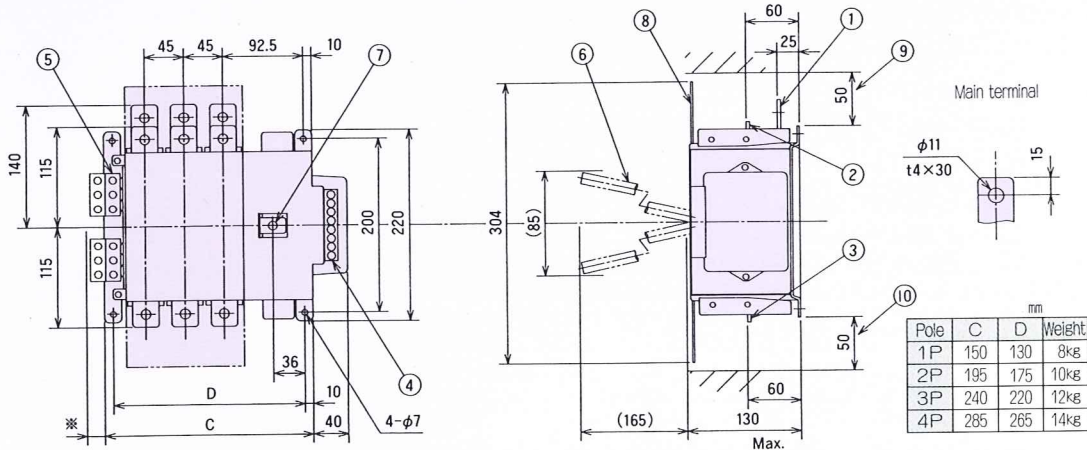

## 300A · 400A

Surface connection type

\* In the case of "with 2c", it will become Max.15.

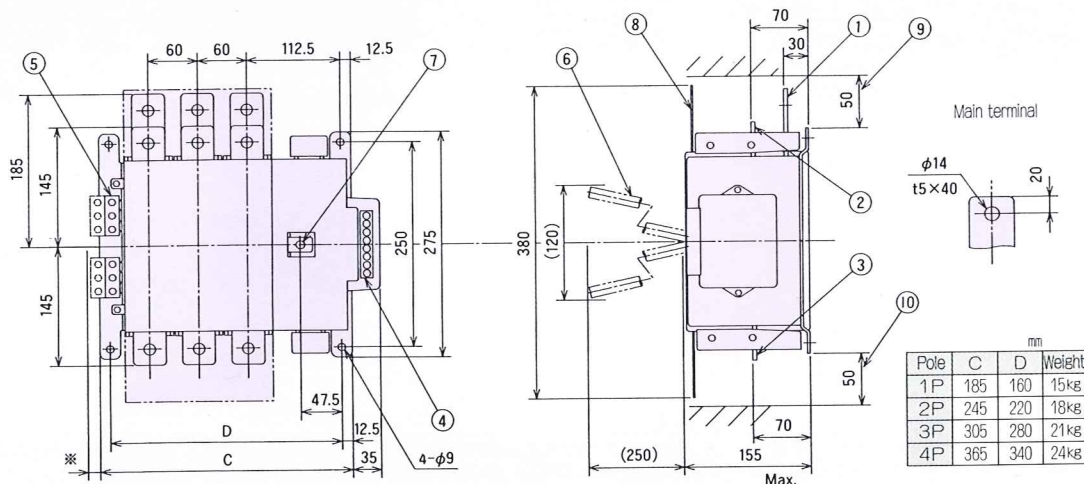



## 500A · 630A

Surface connection type

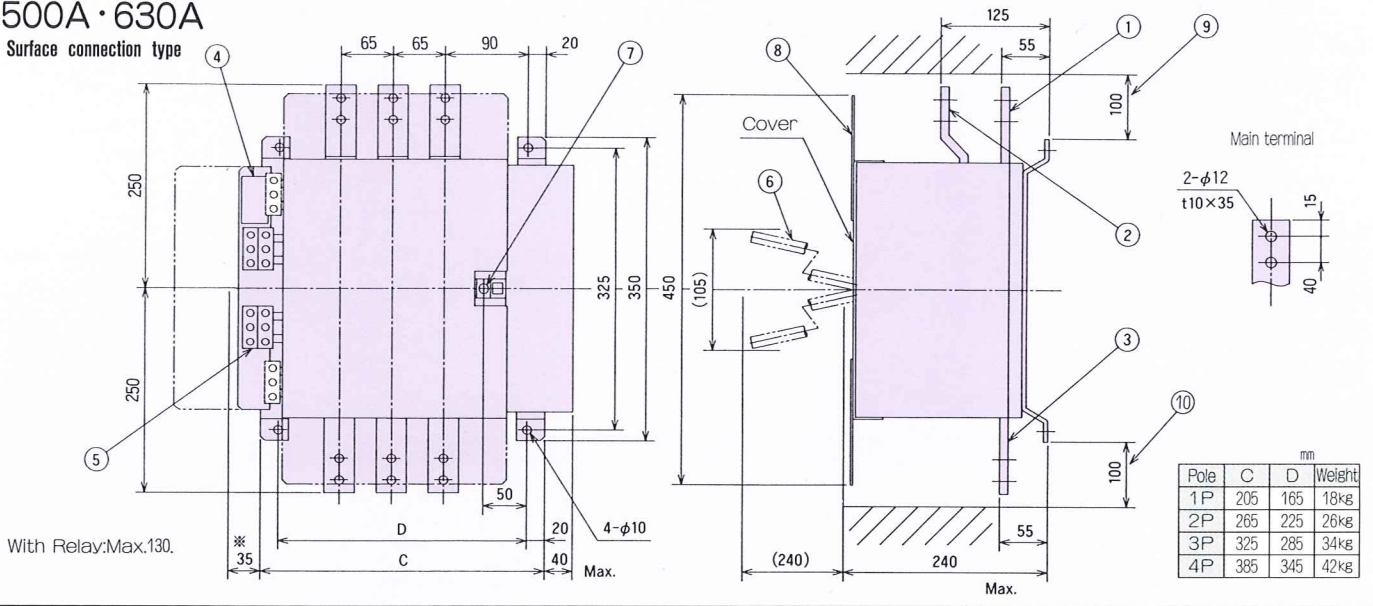

## 800A~1600A

Surface connection type

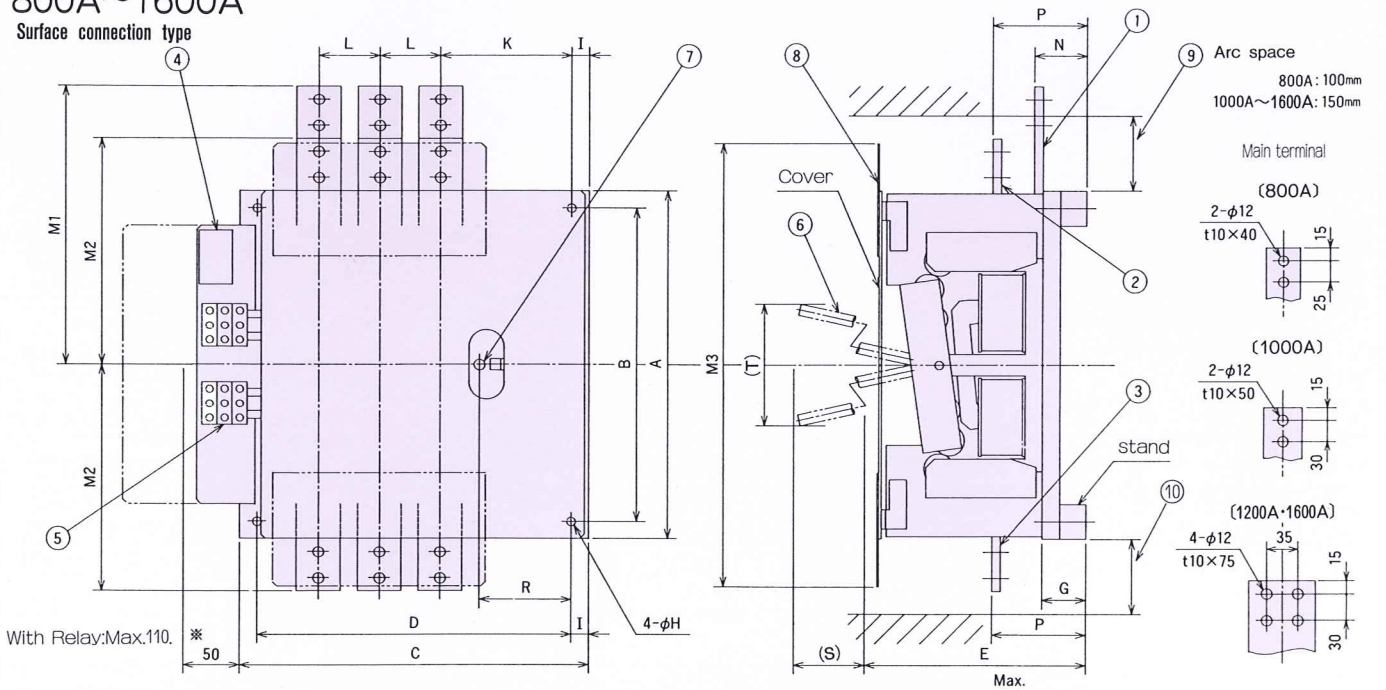

Surface connecting type Panel mounting

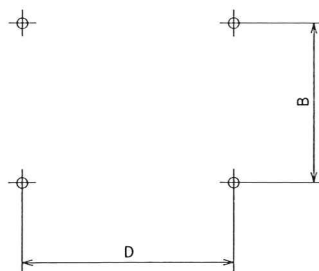

Rated Current	B	D			
		1P	2P	3P	4P
30A 100A	160	110	145	180	215
150A	160	110	145	180	215
200A	200	130	175	220	265
300A 400A	250	160	220	280	340
500A 600A	325	165	225	285	345
800A	360	220	290	360	430
1000A	360	220	290	360	430
1200A 1600A	400	260	360	460	560

# DIMENSIONS

## 200A

### Back connection type

- ① Terminal at load side
- ② Terminal at A power source side
- ③ Terminal at B power source side
- ④ Control terminal
- ⑤ Auxiliary contact
- ⑥ Manual handle (insertion type)
- ⑦ Hole for manual handle
- ⑧ Main terminal cover
- ⑨ Upper side arc space
- ⑩ Lower side arc space

\* In the case of "with 2c", it will become Max.30.

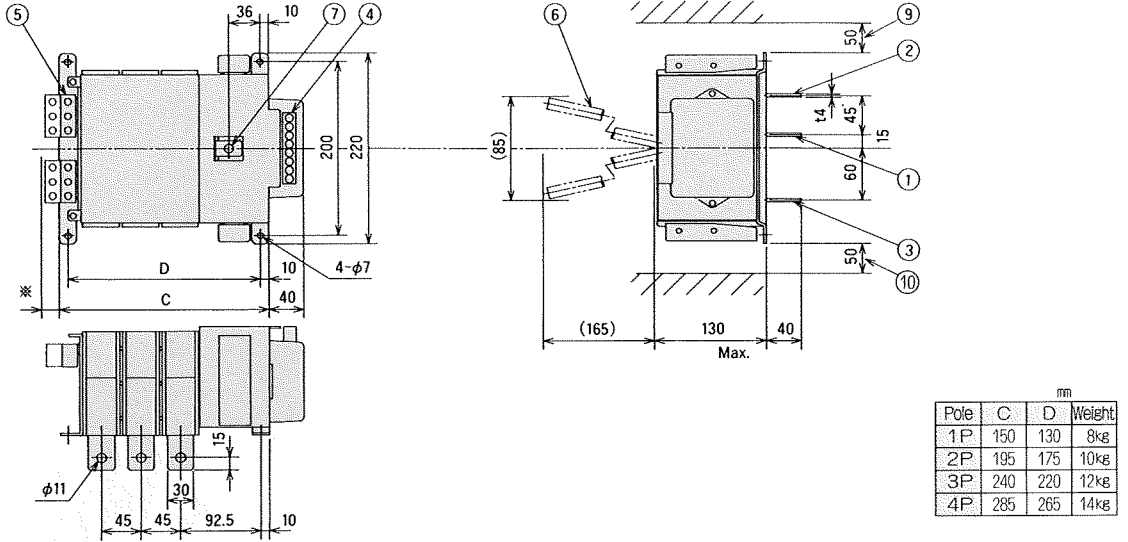

## 300A · 400A

### Back connection type

\* In the case of "with 2c", it will become Max.30.

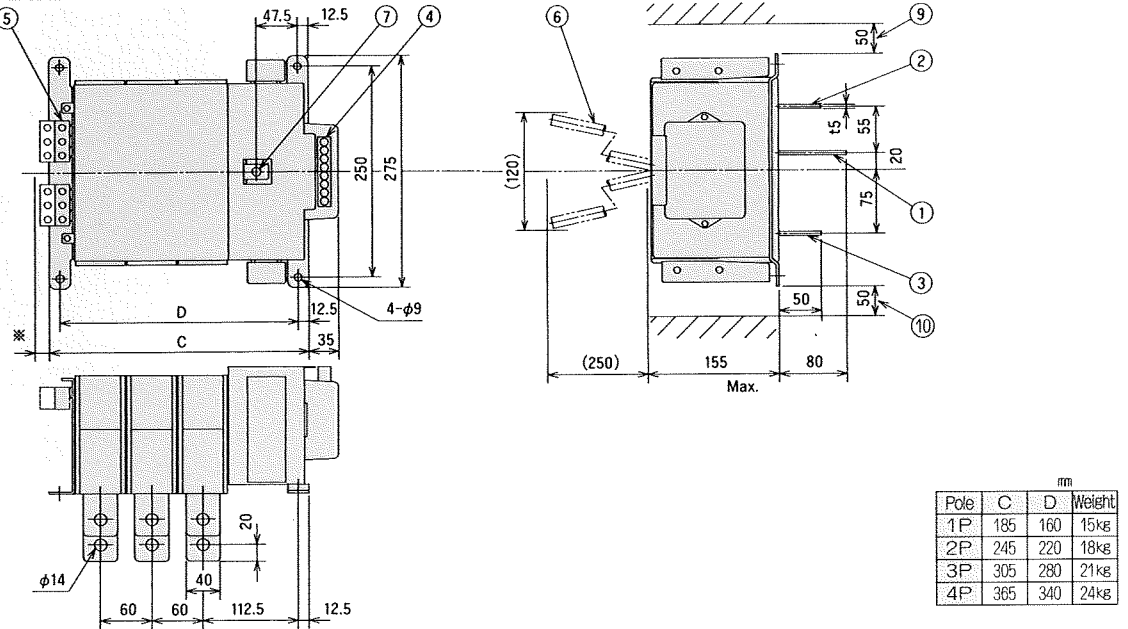

## 500A · 630A

### Back connection type

\* In the case of "with Relay", it will become Max.130.

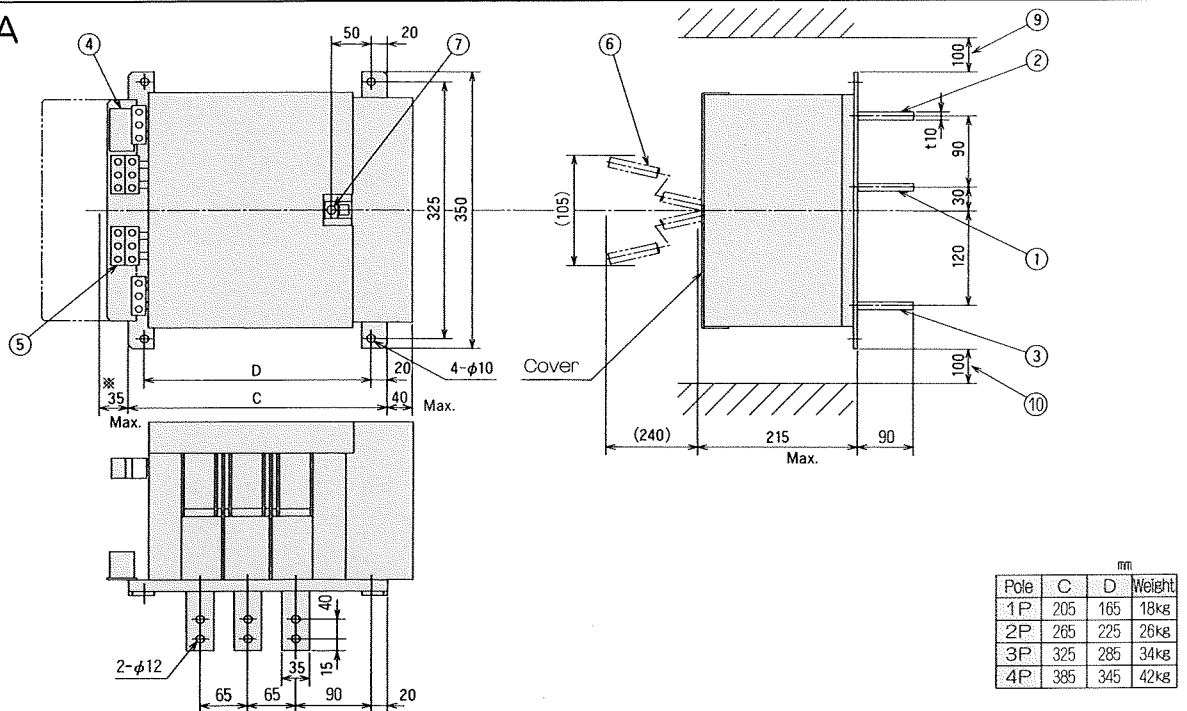

# 800A~3150A

Back connection type

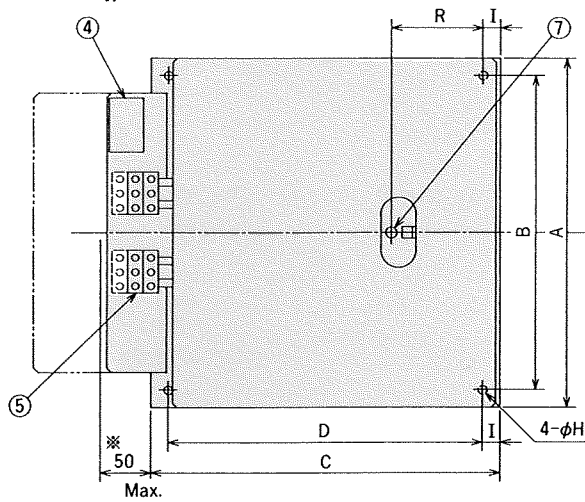

With Relay: Max.110.

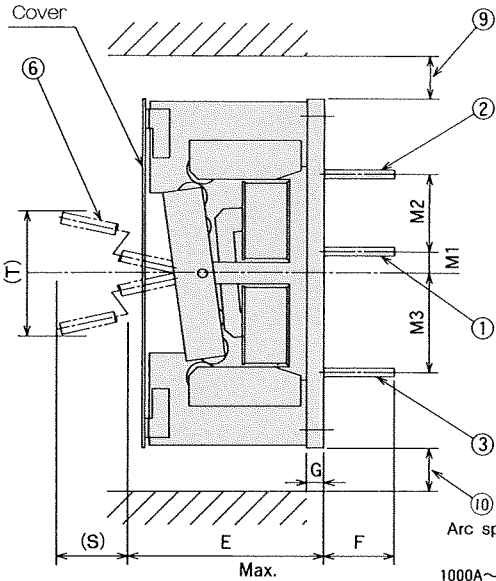

Arc space  
 800A: 100mm  
 1000A~1600A: 150mm  
 2000A~3000A: 200mm

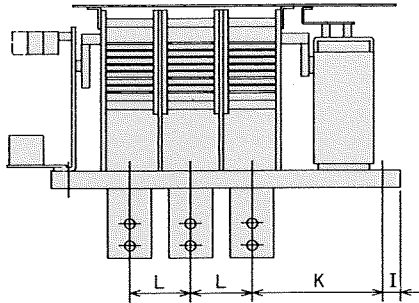

Main terminal

(800A)

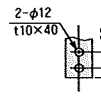

(1000A)

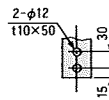

(1200A~1600A)

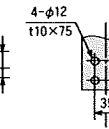

(2000A~2500A)

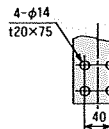

(3000A)

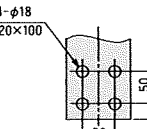

Rated Current	A	B	C				D				φH	E	F	G	I	K	L	M1	M2	M3	R	S	T	Weight			
			1P	2P	3P	4P	1P	2P	3P	4P														1P	2P	3P	4P
800A	400	360	260	330	400	470	220	290	360	430	13	220	70	15	20	150	70	25	89	114	105	395	155	28kg	37kg	46kg	55kg
1000A	400	360	260	330	400	470	220	290	360	430	13	225	80	20	20	150	70	25	89	114	105	395	155	36kg	46kg	56kg	66kg
1200A 1600A	440	400	300	400	500	600	260	360	460	560	13	265	80	25	20	175	100	40	85	125	120	400	160	47kg	65kg	83kg	101kg
2000A 2500A	560	510	330	480	630	780	280	430	580	730	14	285	140	30	25	190	150	10	180	190	125	400	160	75kg	100kg	125kg	150kg
3150A	560	510	330	480	630	—	280	430	580	—	14	285	140	30	25	190	150	10	180	190	125	400	160	80kg	110kg	140kg	—

## Back connecting type Panel cut · Angle mounting

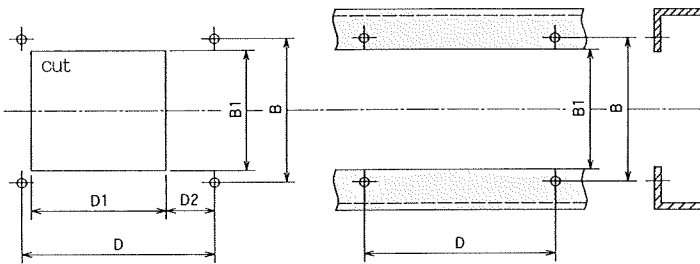

Rated Current	B	B1	D				D1				D2
			1P	2P	3P	4P	1P	2P	3P	4P	
200A	200	170	130	175	220	265	65	110	155	200	60
300A 400A	250	210	160	220	280	340	75	135	195	255	75
500A 630A	325	290	165	225	285	345	195	255	315	375	—
800A	360	330	220	290	360	430	220	290	360	430	—
1000A	360	330	220	290	360	430	220	290	360	430	—
1200A 1600A	400	370	260	360	460	560	260	360	460	560	—
2000A 2500A	510	450	280	430	580	730	280	430	580	730	—
3150A	510	450	280	430	580	—	280	430	580	—	—

## Handle bars dimensions

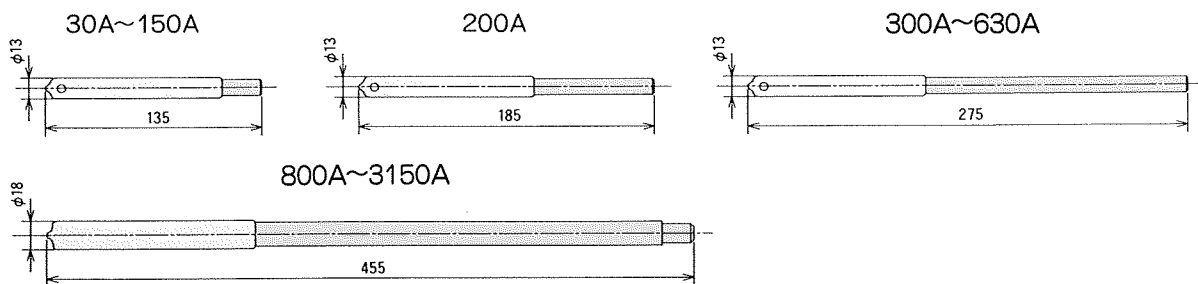

## PURCHASE SYMBOLS

TGMEs 40 3D F A200V 2C RY T  
 ① ② ③ ④ ⑤ ⑥ ⑦ ⑧

- ① Basic type .....TGM-E Type (s is a revision symbol)  
 ② Rated current .....3 : 30A 20 : 200A 40 : 400A 80 : 800A  
 160 : 1600A 315 : 3150A  
 (indicated by 1/10 of the rated current)  
 ③ Constitution of contacts.....3D : 3PDT (3 pole double throw type)  
 ④ Connection system ..... F : Surface connection type  
 B : Back connection type  
 ⑤ Operation voltage  
 A 200V : AC200/220V in common use  
 A 100V : AC100/110V in common use (serving for 50Hz, 60Hz)  
 D 100V : DC100/110V in common use D48V : DC48V D24V : DC24V  
 Examples in case voltages are different:  
 D100V A100V : DC100/110V and AC100/110V  
 It shows the coil ← → It shows the coil at B power side.  
 ⑥ Options : If required, specify. If not required, not shown.  
 2C : With 2C each at up and down sides of auxiliary contacts (all models)  
 RY : With auxiliary relay (built in type) (all models)  
 T : Lower side of terminal at load side (only the surface connection type of 30A-1600A)

## AUXILIARY CONTACTS (OMRON TYPE MICROSWITCH X-10GW-B)

RATED VOLTAGE (V)	NON-INDUCTIVE LOAD (A)				INDUCTIVE LOAD (A)			
	RESISTANCE LOAD		LAMP LOAD		INDUCTION LOAD		MOTOR LOAD	
	NORMALLY CLOSE	NORMALLY OPEN	NORMALLY CLOSE	NORMALLY OPEN	NORMALLY CLOSE	NORMALLY OPEN	NORMALLY CLOSE	NORMALLY OPEN
DC 8	10		3	1.5	10	10	5	2.5
14	10		3	1.5	10	10	5	2.5
30	10		3	1.5	10	10	5	2.5
125	10		3	1.5	7.5	6	5	2.5
250	3		3	0.75	2	1.5	2	1.5

**(NOTE)**

- The these mentioned numeral values show constant currents.
- Induction load is more than 0.4 in power factor and lower than 7 ms in time constant (DC).
- Lamp load means the one with a rush-in current of 10 times as big.
- Motor load means the one with a rush-in current of 6 times as big.
- Even if AC, it is usable at the same electric rating as these mentioned.

## PRODUCTS AVAILABLE

- Automatic Transfer Switches
- Closed Transition Transfer Switches
- Manual Change-over Switches
- DC (Mechanical-held) Contactors
- DC Power Relay
- Power Supplies



**TAKADA WORKS CO., LTD.**

- HEAD OFFICE : 6-1-10 Honkomagome, Bunkyo-ku, Tokyo Japan 113-0021  
TEL 03 (3946) 2566 FAX 03 (3946) 2557
- HANNO PLANT : 980 Iwasawa, Hanno, Saitama Pref. Japan 357-0023  
TEL 0429 (72) 2550 FAX 0429 (72) 2773
- KANSAI OFFICE : 1-2-261 Ikeda-cho, Kita-ku, Osaka 530-0033 Japan  
TEL 06 (6357) 8550 FAX 06 (6357) 8671

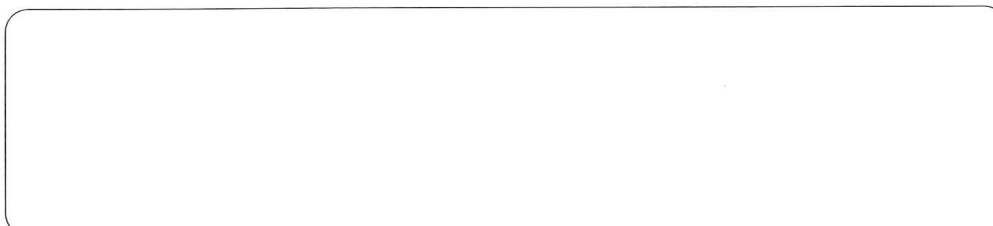

● The specification is subject to change without notice.